



**Important Instructions for all
Cosmetal Ice bank Coolers !**

**Ice Bank Coolers are very different
to Direct Chill or Tank Fed Coolers.**

**Read the first two pages of the
Installation Instructions to ensure
the system is setup correctly.**

Cosmetal Installation Guidance

Caution: If the chiller has been lying down or upside down, leave it upright for at least 4 hours before use.

The below instructions are provided for summary guidance purposes for more detailed information please refer to the manual provided with the unit or download from our website.

- 1. Select a suitable installation site:** Power within 1 metre, Potable water supply, Flat surface, Drainage in case of the Niagara FS or recessed drip trays, allow space around the cooler for ventilation – IN (Under counter) Models will require ventilation in the cupboard. Ensure you have a minimum of 2 bar water pressure and regulate the mains pressure with the pressure reducing valve to 3 bar.
- 2. Connect the plumbing rail (PFRAILKITCOS) to the mains,** follow instructions provided with the kit. If using another kit, ensure you have the correct adapters and tubing before attempting installation. Cosmetal use 8mm fittings (equivalent to 5/16" imperial) on the inlet and 6mm fittings between the IN (under sink) units and the taps. Cosmetal supply the appropriate fittings as above with some 6mm and 8mm tubing. The PFRAILKITCOS plumbing rail has 8mm connections and a Fibredyne filter candle, both of which optimise the flow rate and chlorine removal capacity. Using a PFRAILKIT with Carbon Block Candle, or a PFRAILKITNANO with NANOF Candle requires ¼" diameter pipes. You will need an adapter at the Cosmetal unit's inlet to convert the ¼" to 8mm. The combination of the narrower ¼" pipe and the Carbon Block Candle can affect the flow rate adversely. To mitigate against that you can.
 - Change the Carbon Block Candle for an NANOF Candle which offers higher flow rates and a low pressure drop.
 - Reduce any ¼" pipe length should be as short as possible.
 - Open up the Pressure Regulator to increase the flow if on a low-pressure site.

We recommend you install a **scale removal filter with the Prostream boiler system** in hard water areas. We can supply the Brita C150 filter to facilitate this.

- 3. To fill the ice bank;** refer to the manual for the different methods. Connect the pipe to the ice bank inlet and fill. Most models have a **visual indicator tube** on the back of the unit to identify the correct fill level. This tube can also be used to drain the ice bank before moving or relocation. Fill the ice bank to the max level. The Niagara free standing system does not have a visual indicator tube. Connect the drainage hose supplied at the back and drain into a bucket. Connect the incoming water to the ice bank inlet and fill the ice bank until the water runs from the drainage hose. To drain the Niagara ice bank you need to syphon or pump the water out.

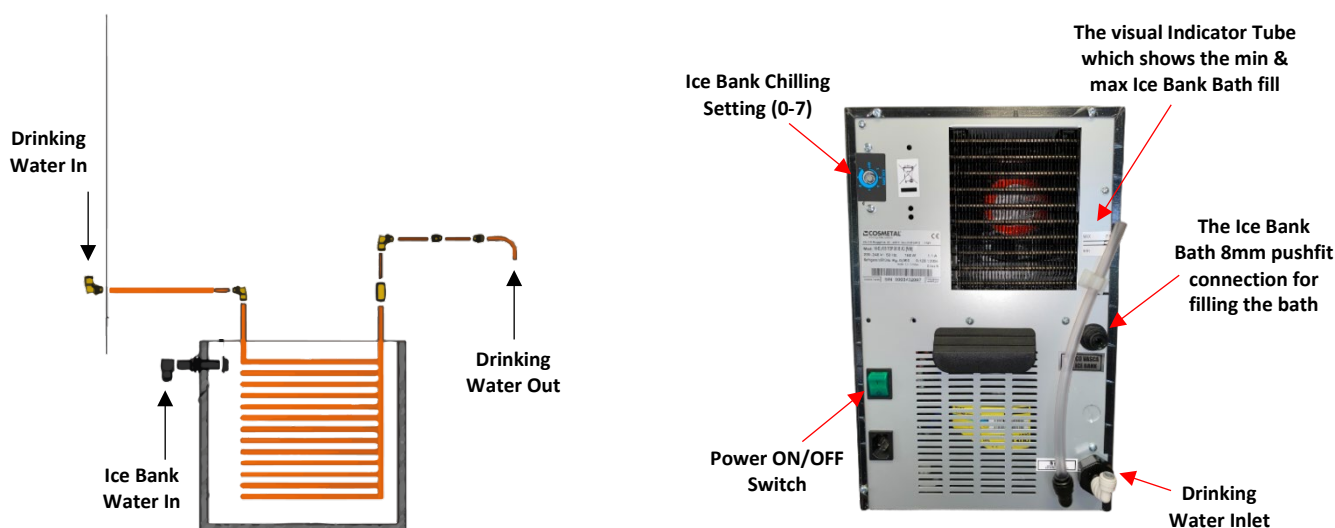

4. Connect the inlet water supply:

Disconnect incoming water feed from the ice bank and connect into the 8mm-5/16" water inlet fitting, located on the back of the cooler. Note some models have a 3/4" male BSP fitting, use the parts provide to adapt to 8mm.

5. Turn the water and power on and dispense water through all taps. Check for any leaks.

6. With Gas versions, connect the CO2 bottle to the CO2 Inlet. The recommended gas pressure should be no greater than 4 bar. Please note the CO2 pressure should be greater than the water pressure. Only turn the gas on after the tank has been filled (see step 5)

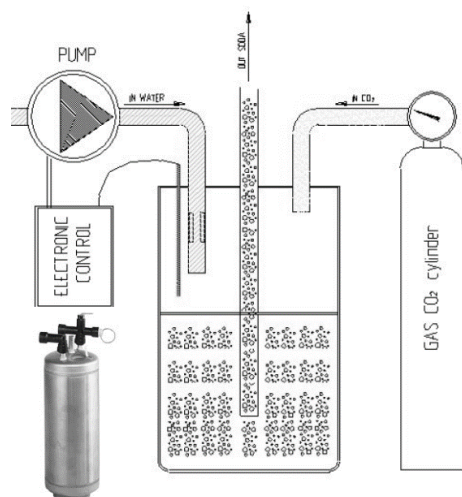

7. Set the thermostat we recommend you set the stat to 5 on the mechanical stats. (all models excluding the electronic control versions) Turn the stat clockwise to 5. Do not set to 7 as this could freeze the Ice bank.



8. Set the thermostat on EC (Electronic Control) versions. Thermostat settings can be adjusted through the control panel. The LCD panel will display the current setting and we recommend you check this during installation. The default settings are +2 C for the summer months and +2 C for the winter. We recommend you set both to +2C if they are not set like this already. Please see the instruction manual for programming instructions. **Failure to set the thermostat correctly could lead to a frozen ice bank and malfunction.**



9. Troubleshooting

EN 10.2 COOLING SYSTEM

ANOMALY	POSSIBLE CAUSE	INTERVENTION
the compressor will not start	- power failure	- check that there is voltage in the plug
	- thermostat on the off position, or set to the minimum	- adjust the thermostat position
	- faulty thermostat	- replace the thermostat
	- the over-load protection of the compressor is faulty	- replace it
	- the starting relay is faulty	- replace it
	- the starting capacitor is faulty	- replace it
	- the compressor is faulty	- replace it
the water is cold but the appliance is operating excessively or non-stop	- little ventilation	- place the appliance away from the wall
	- the condenser is dirty or covered	- clean the condenser or free it of its obstacles
	- the thermostat is on maximum cold position	- adjust it
	- the room temperature is higher than 32°C	- it is normal that the appliance works at a continuously high room temperature
the compressor works continuously, but the water is not cold	- gas leak from the cooling system	- contact a specialised technician (refrigerationist)
	- the compressor is faulty	- replace the compressor
COOLING SYSTEM		
too much noise coming from the appliance, but it is working normally	- the machine is not levelled	- level the appliance using the adjustable feet
	- a few pipes are touching some parts inside the appliance, thus causing it to vibrate	- adjust the position of the pipes, making sure they do not touch any other parts
cold water comes out slowly or not at all	- low pressure of the inlet water	- take steps to increase the pressure (autoclave)
	- faulty solenoid valve	- replace it
	- clogged water filter	- replace it
	- the temperature adjuster is faulty and causes complete freezing of the ice compartment	- make the ice melt. replace the temperature adjuster

CARBONATING SYSTEM		
the carbonated water is not very fizzy or not at all	- the pressure of the gas in the co2 reducer is set to less than 3 bars	- increase up to 3.5 – 4 bars
	- co2 cylinder empty	- replace it
	- the temperature of the outlet water is high	- adjust the position of the thermostat to maximum
	- air bubbles inside the carbonator	- clean out the carbonator
only gas comes out of the carbonated water outlet	- the level probes are dirty	- control and replace
	- the pump turns continuously	- no water is entering or the water filter is blocked
	- the pump turns continuously, inlet water is present	- the pipe fitting into the carbonator is obstructed. disassemble and clean
	- the pump is blocked or the pump-motor is not working	- check it and replace it
	- the level controller is faulty	- control and replace
	- the pump safety device has intervened (no water)	- check that there is pressure in the network disconnect and reconnect the machine from the electrical network to re-set it
continuous dripping from the outlets	- dirty solenoid valve	- disassemble the solenoid valve and clean it
the still water comes out carbonated	- there is a shortage of inlet water	- disassemble and clean or replace

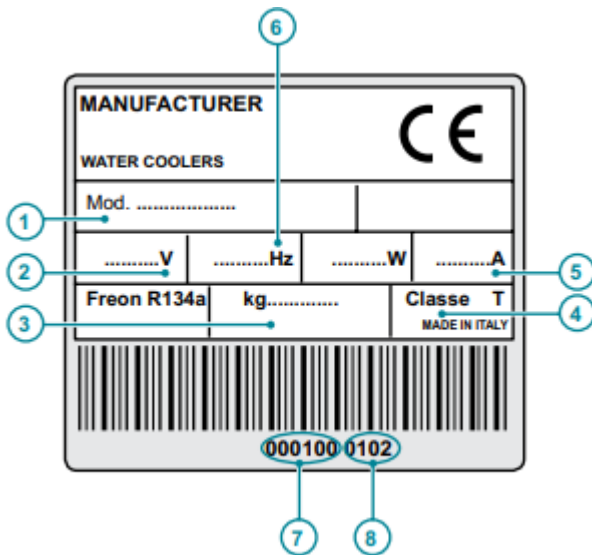

APPLIANCE DATA PLATE

- 1 Model
- 2 Supply voltage
- 3 Quantity of cooling gas
- 4 Class
- 5 Total absorption
- 6 Frequency
- 7 Serial number
- 8 Construction year-month

CONFORMANCE STATEMENT

This appliance has been manufactured with suitable materials for use with drinking water.

This product has been designed, manufactured and placed on the market complying with the following EC conformities:

- Safety objectives of the "Low Voltage" of Directive 2014/35/UE (Ex 2006/95/EEC).
- Protection requirements of Directive, 2014/30/UE (Ex 2004/108/EEC).
- Certified by  TÜV HESSEN

EN 1 BEFORE USING THE APPLIANCE

1.1 WARNINGS



In order to use your appliance to its best, we advise reading these instructions carefully as they contain useful information.

- Keep this book for later use.
- When you have removed the packaging, make sure that the appliance is not damaged. Any damage must be reported to your carrier within 24 hours.



If the machine has been put down or turned upside down, wait for at least 8 hours before putting it into operation.

- Make sure that installation and electrical wiring are carried out by a qualified technician according to the manufacturer's instructions and to the local norms in force. The electrical system must be equipped with an effective earth according to the law (46/90).

1.2 GENERAL PRECAUTIONS AND SUGGESTIONS



Before carrying out any maintenance or cleaning operation, remove the plug from the mains socket.

- Do not pull on the supply cable in order to remove the plug from the socket.
- When the appliance has been installed, make sure it is not resting on the mains supply cable.



The data and characteristics indicated in this manual do not bind the manufacturer, who reserves the right to make all the modifications deemed necessary, without having to give prior notice or replacement.



Failure to comply with any of these safety regulations could cause fires, electric shocks or damage the machine.

PLACE OF INSTALLATION

- This appliance is designed for household and similar uses such as:
 - Kitchen areas of personnel in shops, offices and other working environments;
 - Rural houses and hotel customers, motels and other residential type environments;
 - Areas like bed & breakfast and guest houses;
 - Food services and use at similar retailers.
- Do not place the machine near inflammable solvents such as alcohol or diluents.
- Do not install the machine in excessively damp and dusty places, exposed to direct sunlight, outdoors or near to heat sources. Machine installation in these places could cause fires or electric shocks.
- The appliance is not suitable for use in open places.
- During connection of the appliance to the mains water supply, all pre-existing tubes, gaskets and joints placed between the appliance and the water mains connection must be replaced with new material to avoid contamination.

ELECTRIC POWER SUPPLY

- Do not connect or disconnect the machine from the socket with wet hands.
- Insert the plug into the wall socket firmly.
- Do not damage, modify, stretch, bend or twist the power cable.
- Do not place heavy objects on the power cable.
- Do not connect the machine to a socket to which other equipment is con-

nected (extensions, 2 or 3 plug adaptors, etc.).

- Do not use the machine if the power cable is tied or knotted.
- If smoke, unusual smells or strange noises are found coming from the machine, disconnect it immediately from the socket and contact the local retailer or technical service assistance. Use of the machine in these conditions could cause fires or electric shocks.
- Periodically disconnect the machine from the socket and clean the plug and socket with a dry cloth. If the machine is connected in a place exposed to dust, smoke or high humidity, the dust accumulated on the plug will absorb humidity and this could alter the insulation and trigger a fire.
- Do not spray water on the device; this could cause electric shocks or fires.
- The appliance must not be installed where water jets can be generated.
- Use a damp cloth to clean the machine. Do not use inflammable solvents such as alcohol, benzene or diluents. If inflammable substances come in contact with the electrical components inside the machine, they can cause fires or electric shocks.
- Before cleaning the machine, switch it off and disconnect it from the socket. Not being switched off or accidental switching on during cleaning could cause injuries to persons or damages to the machine.
- The device can be used by children under the age of 8 and by people with reduced physical, sensory or mental capabilities, or lack of experience or knowledge, provided under supervision or after the same have been instructed on the use ensure safe and understanding of the dangers inherent in it. Children should not play with the appliance. Cleaning and maintenance meant to be performed by the user must not be performed by unsupervised children.

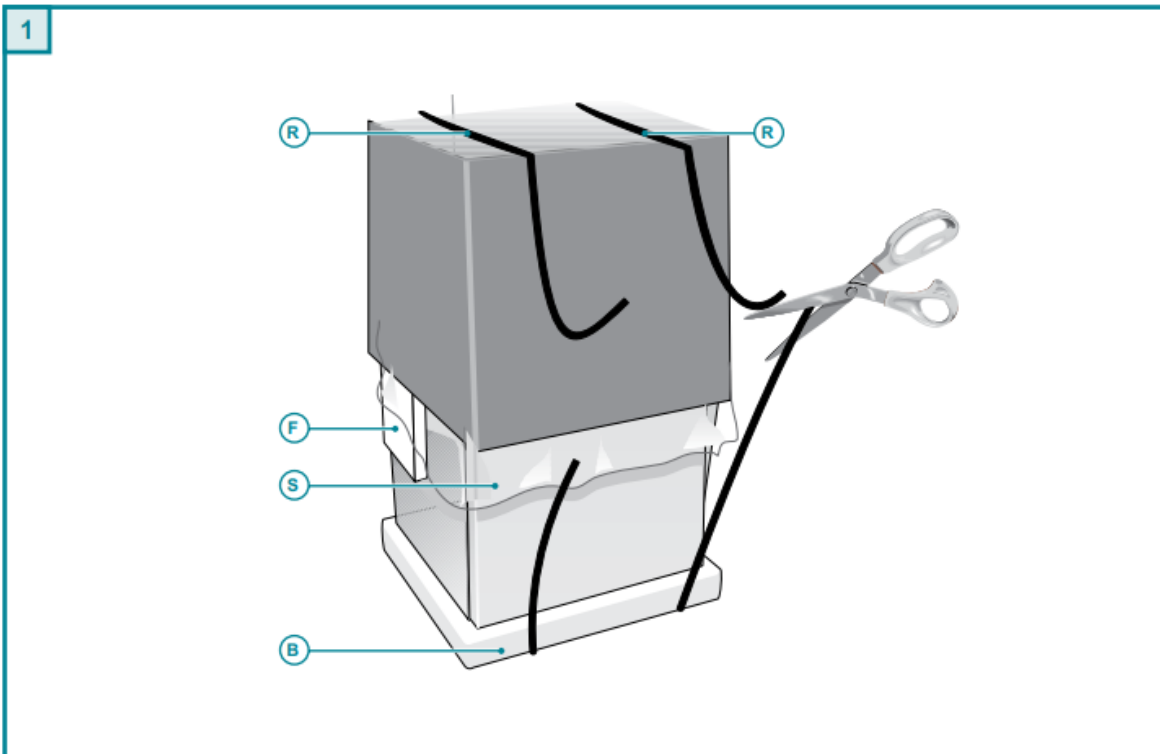

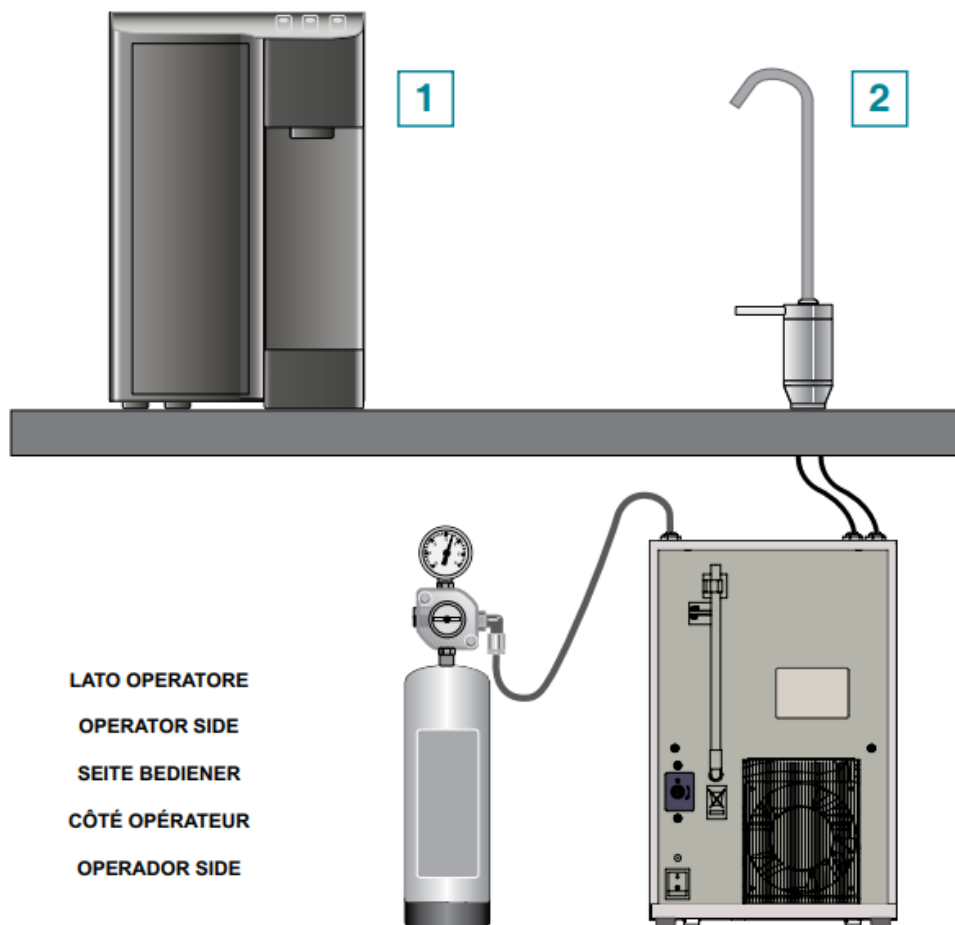

EN 3 DESCRIPTION OF THE APPLIANCE

These water coolers were designed to provide large quantities of still and carbonated cold water and hot.

They are easy to use and manufactured using top quality materials, offering the utmost hygiene and ease of maintenance.

Indicated for household use, it can also be installed in other places like bars and offices. They should always be installed indoors and in the environmental conditions described under the "technical features" heading.

They are equipped with an internal cooling system, capable of supplying water cooled to $3 \pm 10^{\circ}\text{C}$.

They use a direct cooling system (hermetic ice bank).

Two types of water coolers are available:

- Countertop (1)
- Undercounter (2)

Some models can also provide carbonated water, in which case they need to be connected to a CO2 cylinder.

- The countertop models have, as standard, a solenoid valve with safety function (anti-flooding).

(IT) Modello sottobanco - (EN) Undercounter model - (DE) Unterbaummodelle - (FR) Modelé sous plan - (ES) Modelo debajo de mesón

IN ACH
IN CHWG

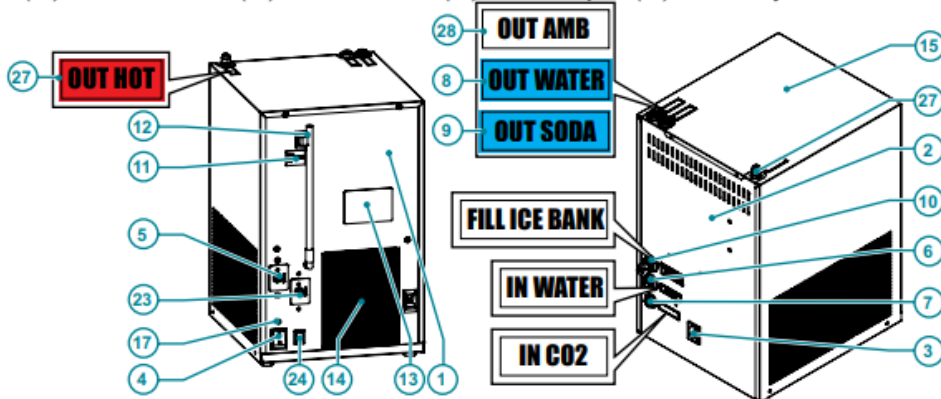

(IT) Modello sottobanco - (EN) Undercounter model - (DE) Unterbaummodelle - (FR) Modelé sous plan - (ES) Modelo debajo de mesón

IN CWG
IN C

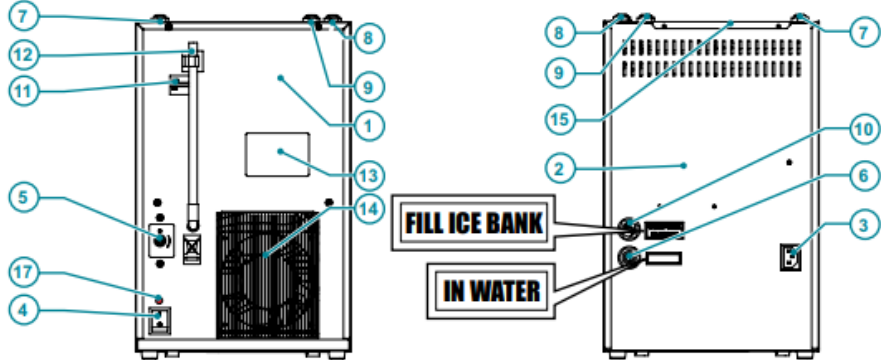

EN

- | | |
|--|---|
| <p>1 Operator side
2 Rear side
3 Electrical power supply socket
4 Main switch
5 Cold water thermostat
6 Mains water inlet 3/4M or ø 8mm
7 CO2 inlet ø 6mm (WG model)
8 Cold water outlet
9 Carbonated water outlet (WG model)
10 Water entrance for basin loading
11 Level and basin unloading tube
12 Basin water level indicator
13 Label bearing the technical data and serial number
14 Heat outlet vent (do not cover)
15 Casing - easily removable to reach interior parts</p> | <p>16 Red floater indicating tray filling
17 Warning light for insufficient water (WG models)
18 Network voltage warning light
19 Cold water button
20 Button for water at room temperature
21 Sparkling water button (WG models)
22 Small tank to collect dripping water. It is removable and can be connected to a drain.
23 Hot water thermostat
24 Hot water switch
25 Hot water buttons (H - HWG models) must be pressed at the same time for distribution
26 LED "HEATING" indicator lights up during the heating phase
27 Hot water outlet (OUT HOT)
28 Output water environment (OUT AMB)</p> |
|--|---|

EN

4 TECHNICAL CHARACTERISTICS

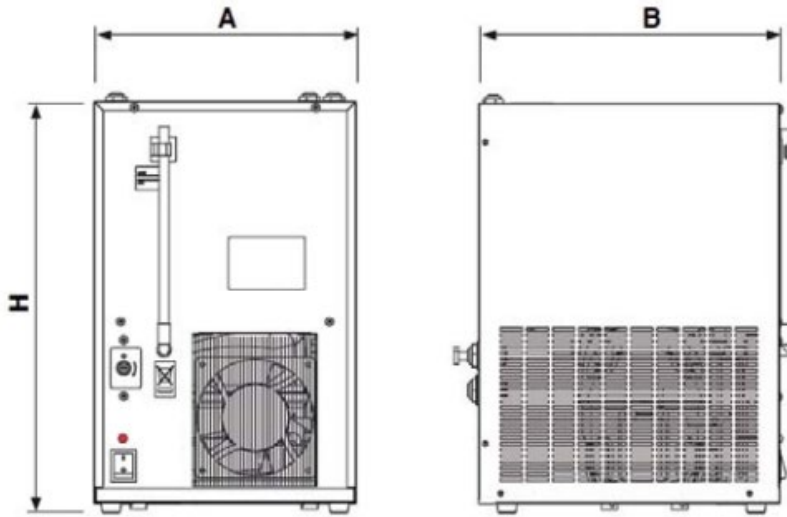

(IT) Modello IN
 (EN) IN model
 (DE) Modell IN
 (FR) Modèle IN
 (ES) Modelo IN

ACH - CWG - CHWG

A	B	H
260	300	407

(IT) Modello IN
 (EN) IN model
 (DE) Modell IN
 (FR) Modèle IN
 (ES) Modelo IN

C

A	B	H
260	235	407

HANDBOOK SECTION II
 Reserved to qualified operators

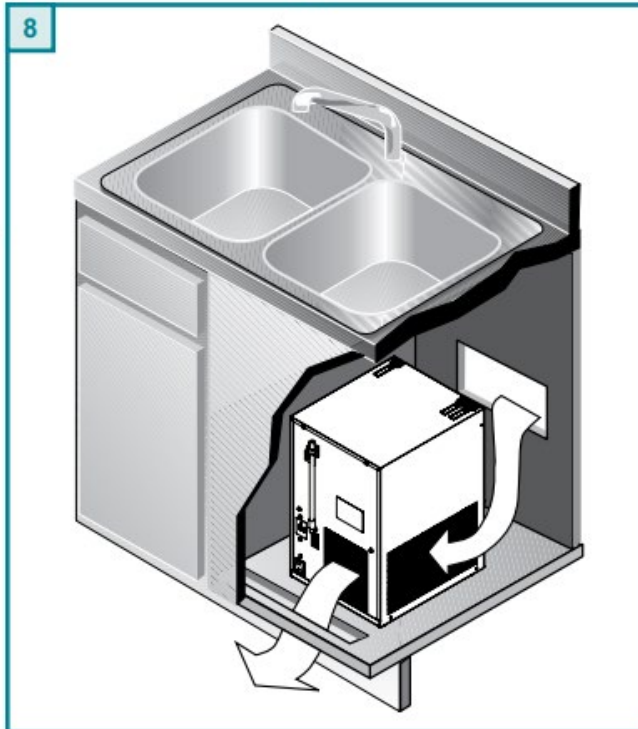
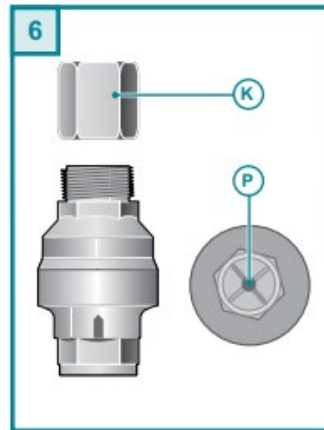
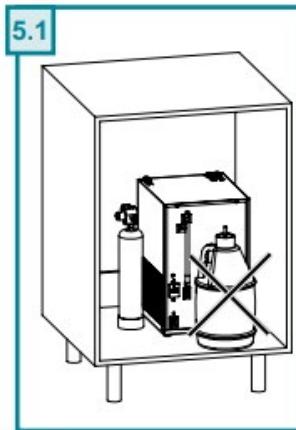

⚠ In fase di collegamento della macchina alla rete idrica, tutti i tubi, guarnizioni e giunzioni preesistenti, posti fra la macchina e la presa dell'acqua di rete, devono essere sostituiti da nuovo materiale per prevenire contaminazioni.

During connection of the appliance to the mains water supply, all pre-existing tubes, gaskets and joints placed between the appliance and the water mains connection must be replaced with new material to avoid contamination.

Beim Anschluss des Gerätes an das Wasserversorgungsnetz müssen alle bestehenden Leitungen, Dichtungen und Verbindungen zwischen dem Gerät und der Wasserentnahme aus dem Wasserversorgungsnetz mit neuen Materialien ausgewechselt werden, um eine Verunreinigung zu vermeiden.

Au cours du raccordement de la machine au réseau hydrique, tous les tuyaux, joints et raccords préexistants, situés entre la machine et la prise de l'eau de réseau, doivent être remplacés par du matériel neuf pour prévenir les contaminations.

En fase de conexión del ma máquina a la red hidrica, todos los tubos, empalmes y juntas existentes ubicados entre la máquina y la toma del agua de red deben ser sustituidos con materiales nuevos para evitar contaminaciones.

EN 5 INSTALLATION

5.1 POSITIONING THE APPLIANCE

Position the appliance in the point of installation, away from sources of heat and direct sunlight. We also advise against installing the appliance outdoors and in very damp rooms.

- Install the machine under the sink, keeping the vent **C** completely clear. Do not put anything in the way that could prevent or restrict the circulation of air (fig.5.1).
- The appliance should be positioned in such a way as to leave approximately 6 + 7 cm of space free for air to circulate freely. Special ventilation grills/slits must be prepared in the undercounter model's housing compartment to favour disposal of the heat produced by the refrigerating circuit (fig.8).
- Make sure the water cooler is resting fully on all four supporting feet.

5.2 WATER CONNECTION TO THE MAINS

Before making the water connection, make sure the mains water pressure is between 1 and 3 bars.

- If the mains pressure is below 1 bar or the flow rate is less than 2 l/min, fit a device capable of increasing the mains pressure (ex: booster pump or equivalent system).

⚠ N.B.: the pressure is especially important for those water coolers fitted with a carbonation device.

- If the mains water pressure exceeds 3 bars, predispose a pressure reducer capable of reducing the latter to the 1+3 range.
- This water dispenser can be equipped with a WATER BLOCK anti-flooding device (optional) to prevent any accidental water leaks (fig.6). Once the WATER BLOCK device has intervened, fitting **K** should be disassembled and button **P** pressed to reset the device.
- If instead of being connected directly to the aqueduct the machine is connected to an autoclave pump, then it is necessary to install above the water supply an ANTISHOCK device to prevent "water hammers" (fig. 7).

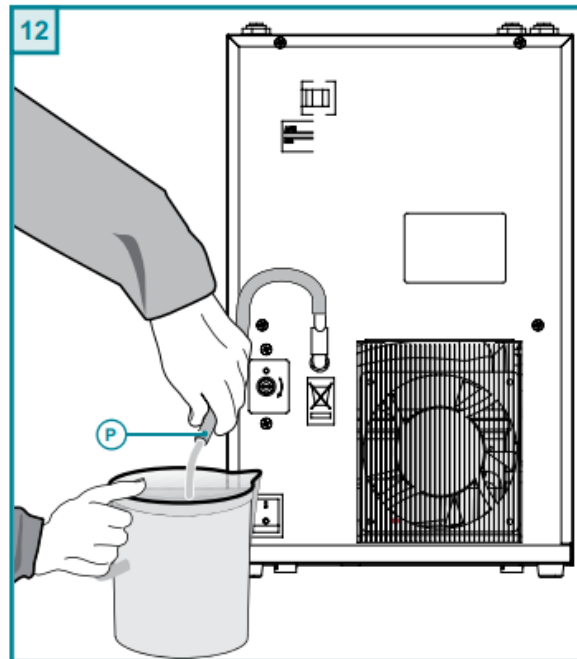
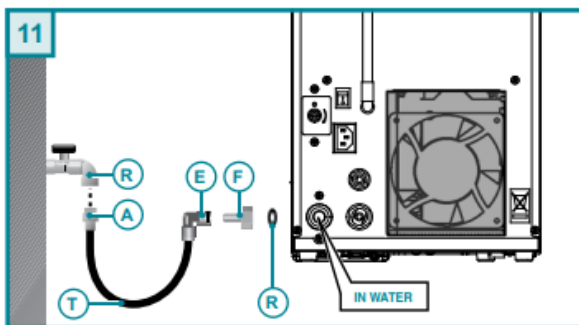
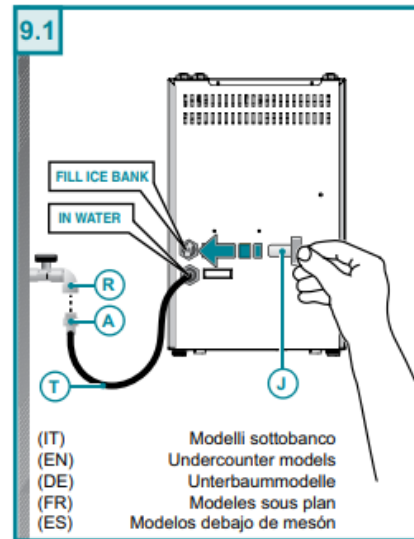
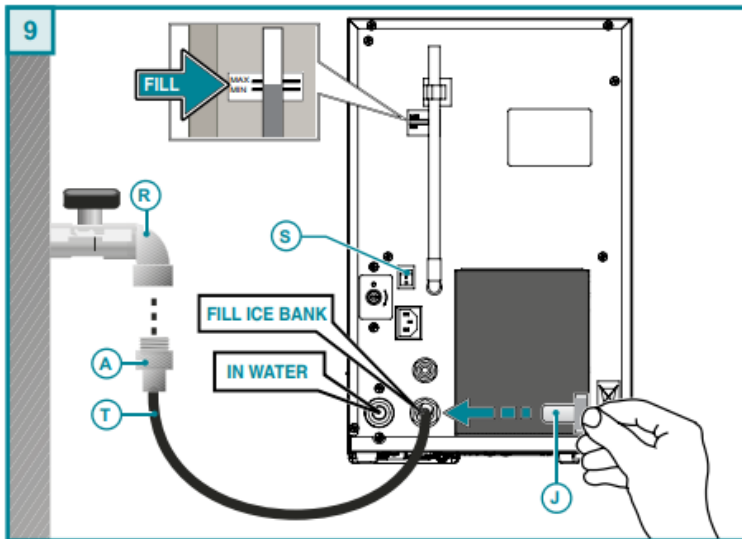

EN

Connection to the water mains is done using the **T** tube provided (8 mm diameter) and the **A** fitting provided. During connection of the appliance to the mains water supply, all pre-existing tubes, gaskets and joints placed between the appliance and the water mains connection must be replaced with new material to avoid contamination.

5.3 ICE CONTAINER FILLING

Turn off the S switch (to '0') on the machine beforehand.

Push tube **T** in the connection **IN WATER** with the necessary pressure.

Open tap **R** and allow water to enter ice bank slowly until the water level in the vertical transparent (Fig. 9) pipe (**P**) reaches the position shown by plate "Fill". Close tap **R**. Take off the tube **T** pushing with a 8 key on the locking ring and simultaneously pulling the tube (Fig. 10). Insert immediately the red cap **J** on the connection **FILL ICE BANK** with the right pressure.

5.3.1 Water connection

Countertop models: Join elements **A, T, E, F, G** (Fig.11).

Undercounter models: Push pipe **T** onto coupling **11** exerting the correct amount of pressure (Fig. 9.1).

5.3.2 Ice container emptying (for maintenance)

Disconnect the power supply cable from the outlet. To empty the ice tank after the ice melted, you just have to take the vertical level and tank discharge tube **P** off its site and let the water flow (fig. 12). After the ice container has been emptied (almost 3 litres), replace the tube in its place.

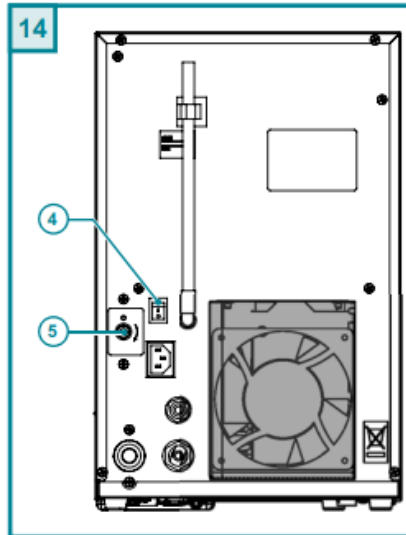
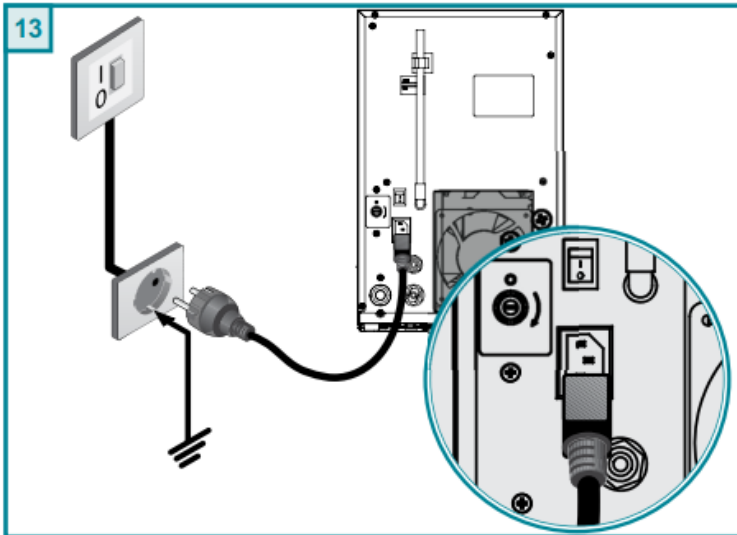

⚠ **Attenzione!** Prima di utilizzare la macchina procedere alla sanificazione (vedi paragrafo relativo).

Warning! Before using the machine proceed with the sanitation (see relative paragraph).

Achtung! Vor der Verwendung der Maschine ist eine Stellisierung auszuführen (siehe entsprechenden Abschnitt).

Attention! Avant d'utiliser la machine procéder à la désinfection de cette dernière (voir le paragraphe relatif).

¡Atención! Antes de utilizar la máquina, proceda a la sanitización (ver párrafo correspondiente).

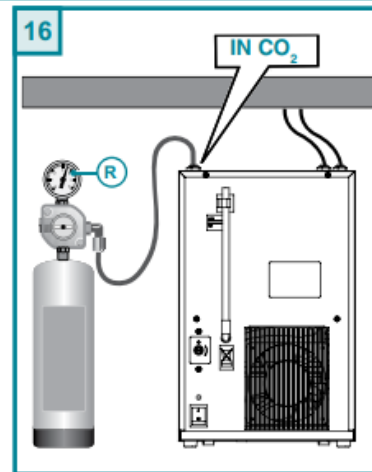
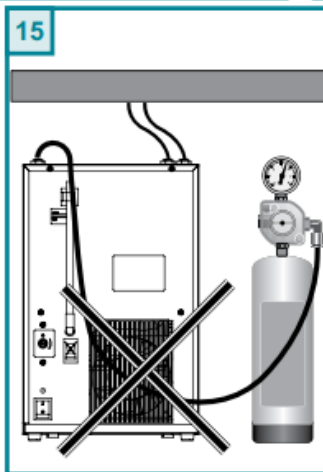

EN 6 STARTING

⚠ **Warning!** If the appliance has been laid down or turned upside down, you should wait at least 8 hours before starting it.

6.1 ELECTRICITY CONNECTION

Connection to the mains electricity supply is carried out by connecting the plug to a mains socket. The supply socket must be equipped with an efficient earth plate and it must be sized for the load of the appliance (see technical characteristics).

Make sure that the mains voltage corresponds with what is specified on the data plate. Make sure that there is an omnipolar switch above the socket with a minimum contact break of 3 mm protected by fuses of suitable amperage for the absorption of the appliance itself (see technical characteristics and data plate).

- Turn on the water tap and make sure there are no leaks.
- Turn on the main ON/OFF switch **4**.
- Turn the tap to the position marked  to eliminate all remaining air in the soda water circuit (WG models).

EN 6 STARTING

- Turn the tap to the position marked  to eliminate all remaining air in the cold water circuit.
- Adjust cold water thermostat **5** depending on use and season (positions recommended from 4 to 7).
- Connect the machine to a mains electrical network protected by a circuit breaker with a sensitivity equal to or less than 30 mA.

6.2 CO₂ GAS CYLINDER CONNECTION (CARBON DIOXIDE)

In this water cooler model, the CO₂ can be connected only outside the machine (fig.18) allowing the use of rechargeable cylinders as well.

CAUTION: do not pass the cylinder's connecting pipe in front of the heat outlet vent (fig. 15).

- Take the $\varnothing 6$ mm pipe out of the installation kit and connect it to the **R** pressure reducer on the cylinder (fig. 16).
- Insert the other end of the pipe on the IN CO₂ connector at the top of the device; make sure you insert it correctly.

The cylinder is provided with a sealing valve which will open during reducer assembly and will close automatically during disconnection. The reducer regulation screw **R** is already calibrated in the optimal pressure setting (approximately 3.5 bar). In any case, the quantity of gas supplied can be increased by turning the screw in the clockwise direction, and vice versa. 600 g. rechargeable CO₂ cylinders can charge approximately 120 liters of water.

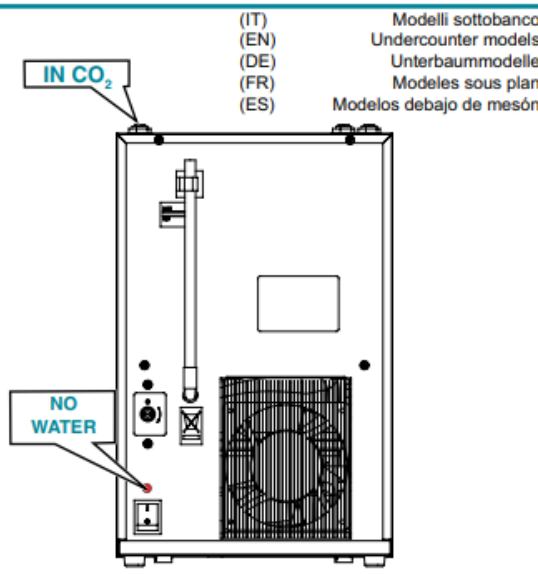
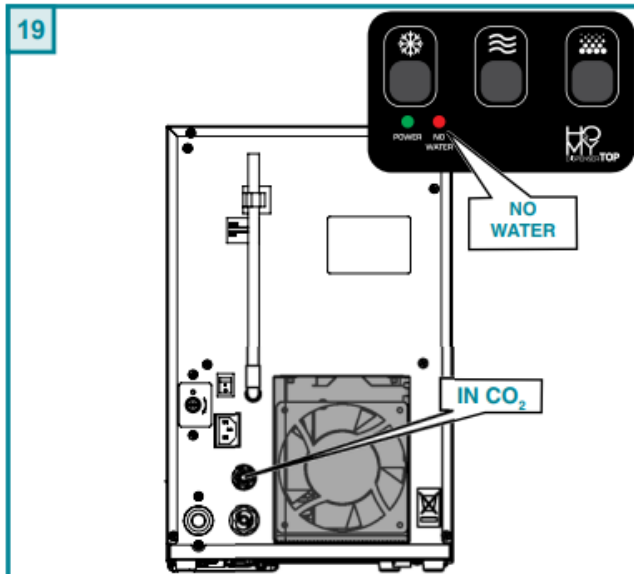
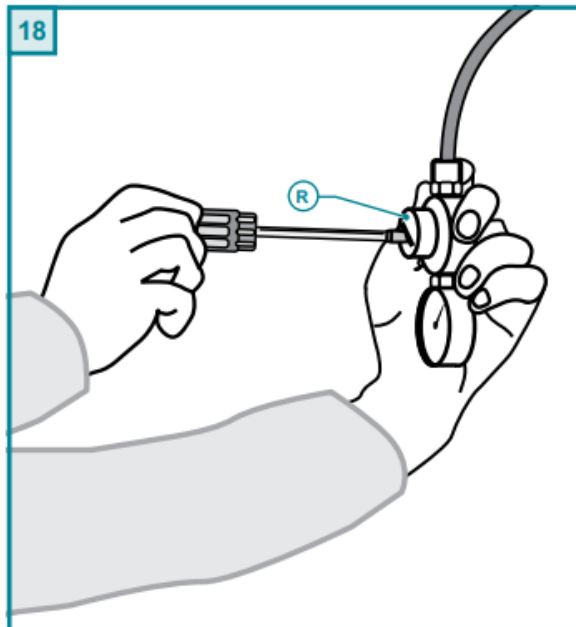
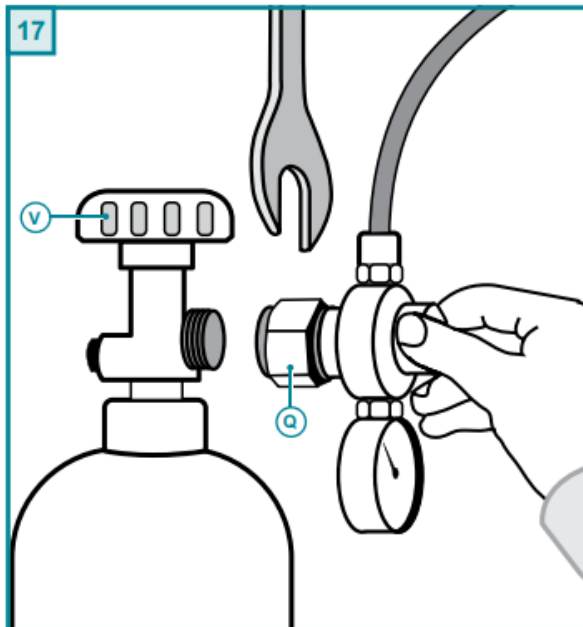

(IT) Modelli sottobanco
 (EN) Undercounter models
 (DE) Unterbaumodelle
 (FR) Modèles sous plan
 (ES) Modelos debajo de mesón

EN 6 SETTING UP THE SPARKLING WATER

INSTALLATION OF RECHARGEABLE CYLINDERS (B-RIC)

- It is also possible to install refillable cylinders (B-RIC).
- Remove the ø6mm tube from the installation kit and connect it to the pressure reducer **R** of the rechargeable (B-RIC) cylinder to the IN CO₂ inlet on the top panel (fig.19).
- Screw the pressure reducer cap to the cylinder attachment paying attention to the gasket.
- Open the cylinder valve **V**.

The screw for regulating the reduction valve **R** has already been calibrated to the optimal pressure setting (approximately 3,5 bar).

In any case, the quantity of gas supplied can be increased by turning the screw in the clockwise direction, or decreased by turning it in the anti-clockwise direction (fig.18). Rechargeable CO₂ cylinders can charge approximately 140 liters of water.



NOTICE! Rechargeable cylinders are empty when supplied. Have the cylinder filled with gas by the nearest authorized distributor. Ask only for CO₂ (carbon dioxide) for "food products."

To start the carbonation device:

- Press the pushbutton for carbonated water .
- Let a few litres of water flow until carbonated water begins to come out.



Attention!

The results of pressure variations on carbonation will only have effect when at least 2 litres of water have been drained off.

Advice on using the appliance for carbonated water

To guarantee the correct operation of the pump in time, the appliance must always be operated with water in the cooling circuit.

If mains water is insufficient, a protection system intervenes and blocks pump functioning (the NO WATER warning light is illuminated)

To restore functioning the apparatus must be disconnected from the electrical network and reconnected when there is sufficient water in the mains system.

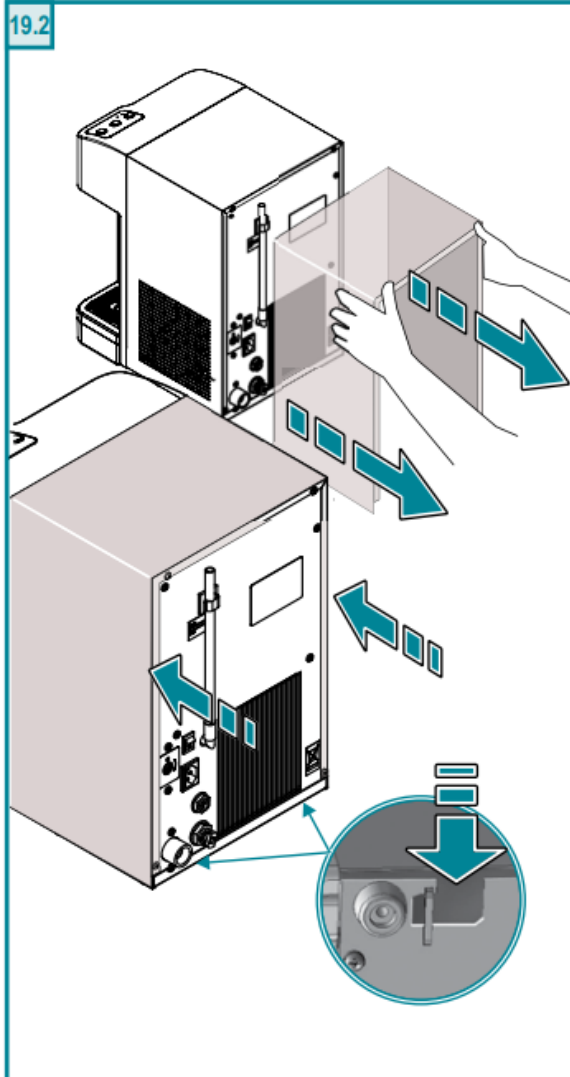
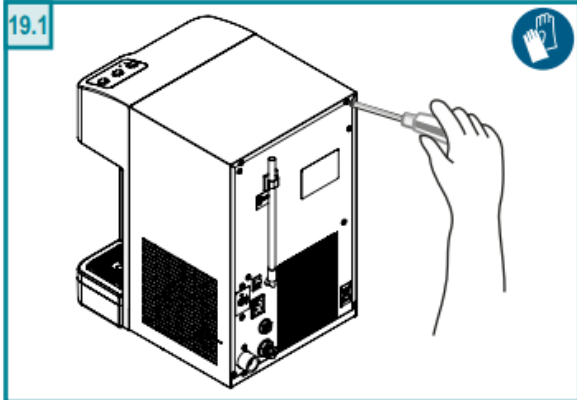

Attenzione: per questa operazione di manutenzione, come per altre che comportano l'apertura dell'involucro macchina, usare guanti protettivi per prevenire il pericolo di bordi taglienti delle lamiere

Attention: to carry out this or any other maintenance operation requiring the machine casing to be opened, use protective gloves to avoid being cut by the sharp edges of the sheet steel

Achtung: für diesen Wartungseingriff müssen, wie für alle, die ein Öffnen des Maschinengehäuses erfordern, Schutzhandschuhe getragen werden, um der Gefahr, sich an den scharfen Rändern der Bleche zu schneiden, vorzubeugen.

Attention: pour cette opération de maintenance, comme pour d'autres qui impliquent l'ouverture de l'enveloppe de la machine, utiliser des gants de protection afin de prévenir le risque lié aux bords coupants des tôles

Atención: para esta operación de mantenimiento y para otras que comportan la apertura de la envoltura de la máquina, use guantes de protección para prevenir el peligro de bordes cortantes de las chapas

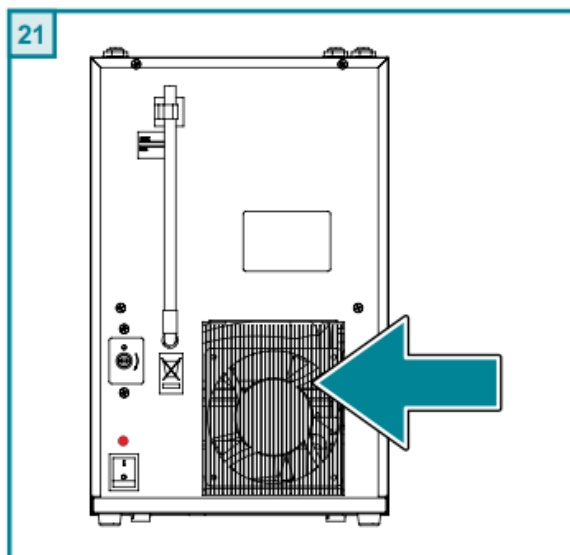

EN

The quality of the carbonation process also depends on the temperature of the water, which means you should wait for the water cooler to have cooled the water down sufficiently upon installation and the ice bank has been formed. Both still and carbonated water can be dispensed by pressing the relative buttons after approximately 40 minutes.

NOTICE

CAUTION! AFTER TRANSPORTING, STORING AND USING CO₂ CYLINDERS, FOLLOW LOCAL REGULATIONS CONCERNING THEIR USE.

6.3 CARBONATION DEVICE DRAINAGE

When installing the appliance, or if the water cooler has no water left inside it, a few air bubbles may enter the carbonation device.

These air bubbles could diminish the quality of the carbonation process, and we therefore recommend you remove them:

- Unscrew the cylinder from the reducer
- Remove the casing
- Drain the circuit by pulling the outlet valve ring **V** (fig.20).
- Re-connect CO₂ cylinder to the reducer
- Drain off at least two litres of sparkling water
- Replace the casing.

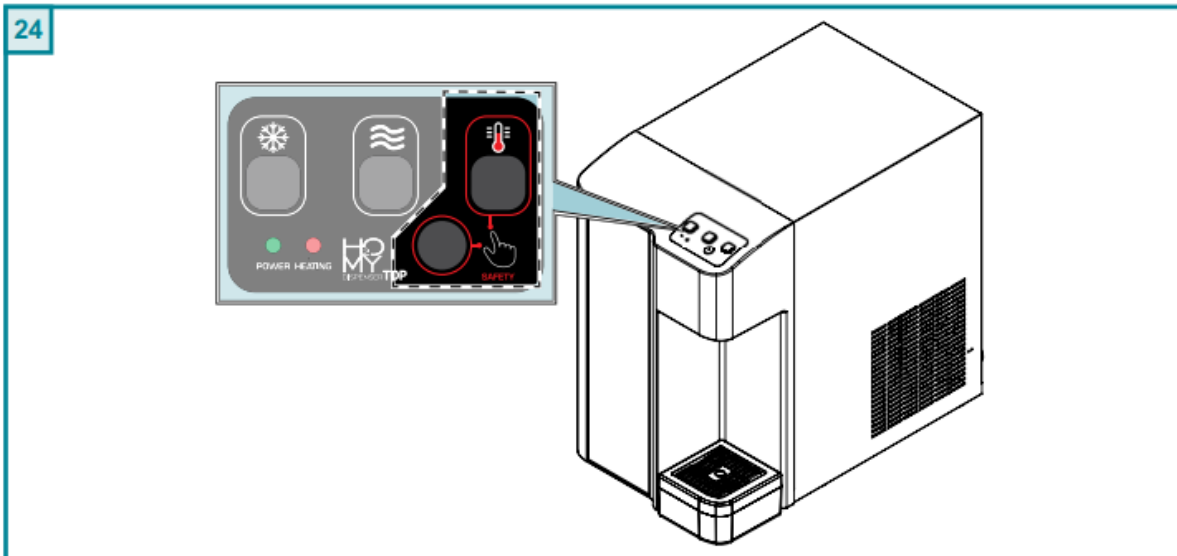
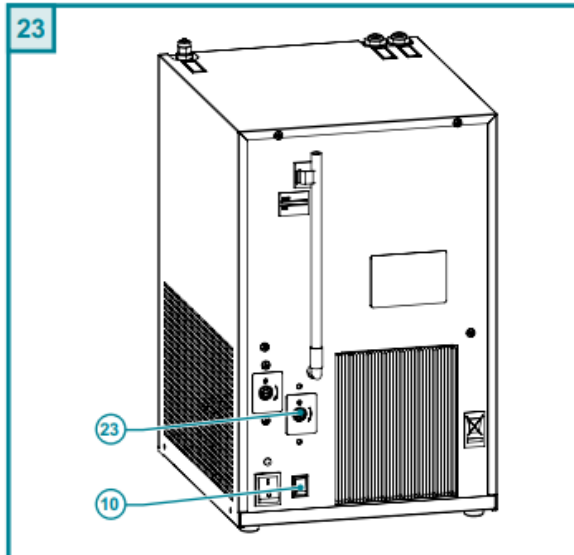
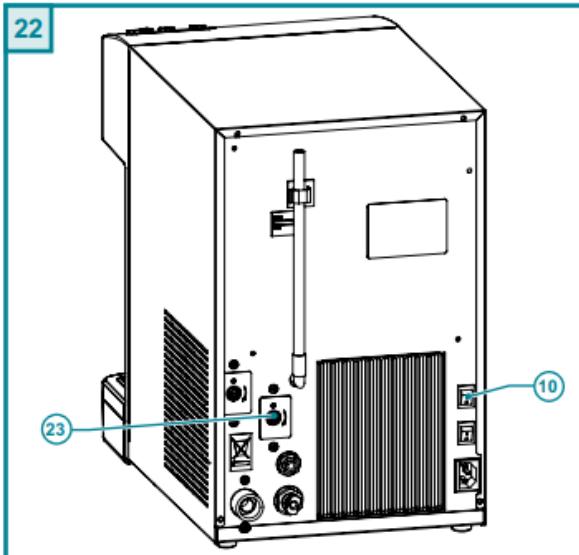

EN 6 STARTING WITH HOT WATER

These water coolers are fitted with a 1.0 litre stainless steel tank for the production and storage of water heated to 95°C max.

A special safety system allows for hot water to be dispensed only if both the

ⓘ button and SAFETY buttons (red button) are pressed simultaneously.

- Identify the red switch **10**; on the TOP model it is placed on the back (fig.22) while on the IN model it is on the operator side panel (fig.23)
- Keep the switch off **10** (pos.O).
- Keep the buttons ⓘ and SAFETY pressed at the same time to fill the tank with hot water, until a constant flow exits the dispenser.

⚠ This is extremely important and should be done before you turn switch 10 on, to avoid any permanent damage being caused to the hot water tank.

- Turn on switch **10**.
- Set the desired temperature on thermostat **23**; the temperature can be set from a minimum of 60°C to a maximum of 95°C. The **23** thermostat is placed on the back on the TOP models and on the IN models.
- When switch **10** turns off, the water has reached the required temperature.

⚠ Warning!
Hot water at 95°C produces steam under pressure.

6.3 HYGIENIC CLEANING

- Once you have checked that the appliance operates correctly, proceed with the "internal cleaning and hygienic cleaning" phase as described in chap. 8.



⚠ Le operazioni di manutenzione devono essere compiute da personale qualificato.
Maintenance operations should be carried out by a qualified professional.
Die Wartungsarbeiten dürfen nur durch Fachpersonal durchgeführt werden.
Les opérations d'entretien doivent être effectuées par du personnel qualifié.
Las operaciones de mantenimiento deben ser ejecutadas por personal calificado.

EN 7 ROUTINE MAINTENANCE

SUBJECT	HOW	HOW OFTEN
Cleaning the outside of the appliance	• Clean the external part with a damp cloth, do not use solvents or abrasive detergents.	Monthly
Replacing the CO2 cylinders	• Follow the instructions provided in paragraph 6.2.	When the manometer falls below 1 bar.
Cleaning the water collection tray	• Clean the tray and remove any residue.	Weekly
Cleaning the cooling condenser (fig.21)	• Remove all dust and dirt with a domestic vacuum cleaner or similar appliance. • Do not use compressed air jets. • Do not use wire brushes.	Monthly
Water replacement in the ice bank tank	• Switch the apparatus off and wait about 1 hour for it to defrost. • Empty the water using the level and basin unloading tube P (see section 5.3.2) • Restore the water level in the ice bank tank as described in the INSTALLATION chapter.	If the machine has been turned off for a long time
Power lead	• Check the condition and intactness of the power lead.	
Water connection check	• Check the condition and intactness of the water supply pipe. • Check for any leak.	
Cleaning the mechanical water filter (TOP models)	• Disassemble the inlet pipe fitting, pull the filter using pliers and remove any impurities (fig. 25.1).	Every month
Cleaning the water dispensing spouts	• Remove the steel nozzle using the appropriate spanner and eliminate all the limestone with a food descaling solution (fig. 25.2).	Depending on the hardness of the water from the mains
Decalcification the machine	• Check and if necessary descaling the water supply hose and filter.	Annually

26

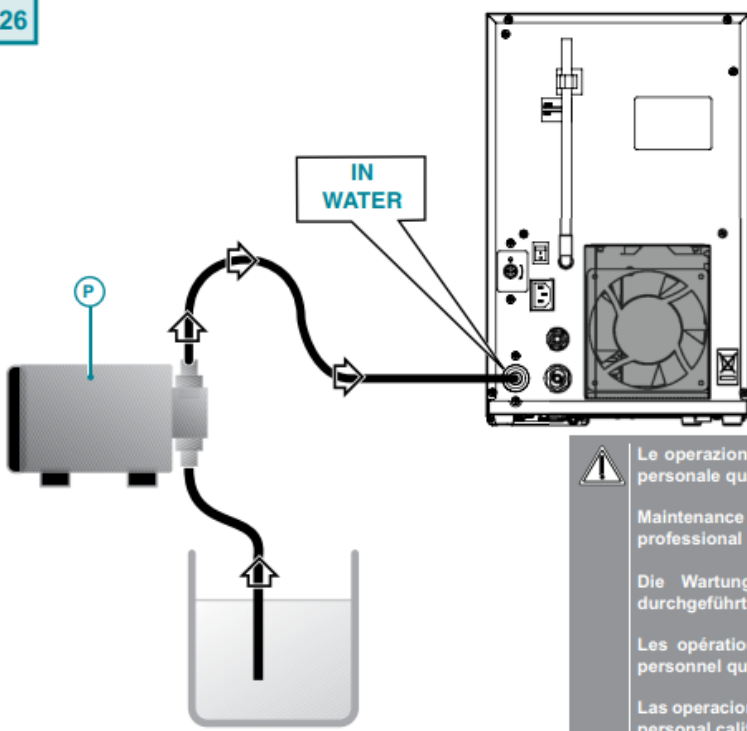

Le operazioni di manutenzione devono essere compiute da personale qualificato

Maintenance operations should be carried out by a qualified professional

Die Wartungsarbeiten dürfen nur durch Fachpersonal durchgeführt werden

Les opérations d'entretien doivent être effectuées par du personnel qualifié

Las operaciones de mantenimiento deben ser ejecutadas por personal calificado

EN 8 INTERNAL CLEANING/HYGIENIC CLEANING

8.1 HYGIENIC CLEANING

WARNING! Given that the products used for the hygienic cleaning procedure contain corrosive acidic and alkaline substances, disposable gloves and protective eye wear should be worn at all times. When performing the hygienic cleaning procedure, please keep to the product reaction times, sanitising liquid percentages and quantities of water for rinsing.

- The operation of higienization/sterilization has to be carried out every time the refrigerator is installed and:
 - every 6 months when it is used (*).
 - every time the water filter is changed.
 - after an inoperative period of one or more weeks.
- (*) If the refrigerator is installed in Hospitals, Schools, Old people's homes, or Clinics, it is recommended to sterilize it every 3 months.

Hygienic cleaning solution preparation

- Prepare 5 litres of water.
- Add to it 5% of "hydrogen peroxide" at 100 volumes; for the doses, use a graded measure or an ordinary syringe.

NB: if you use commercial hygienic cleaning solutions, keep to the instructions provided by the manufacturer and included in the package.

- With the help of a pump **P**, connect the appliance's water inlet to the container with the disinfecting solution.
- Start the pump, allowing the disinfectant to enter the appliance, then turn on the taps to enable the hygienic cleaning solution to flow throughout the entire hydraulic circuit, right through to the water dispensing spout.
- Before the solution runs out, stop the pump and interrupt the dispensing.
- Leave the solution to do its work for minimum 20 minutes.
- Reconnect the appliance to the mains water supply.
- Let at least 15 litres of water flow out of the taps so as to rinse the hydraulic system suitably, before using the appliance again.

8.2 LIMESCALE REMOVAL (H model)

- Limescale should be removed from the hot water tank regularly, to avoid the build-up of limescale deposits. This should be done at least once a year or when you notice that hot water has some difficulty flowing out.



Le operazioni di manutenzione devono essere compiute da personale qualificato

Maintenance operations should be carried out by a qualified professional

Die Wartungsarbeiten dürfen nur durch Fachpersonal durchgeführt werden

Les opérations d'entretien doivent être effectuées par du personnel qualifié

Las operaciones de mantenimiento deben ser ejecutadas por personal calificado

27

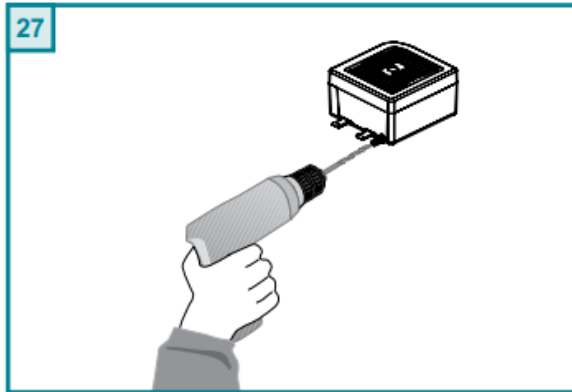

EN 10 FAULTS AND REMEDIES



Warning! The operations should be carried out by a qualified professional.

10.1 DIAGNOSIS AND OPERATING ANOMALIES

This section includes the typical anomalies that could occur.

Many of these problems are not caused by the cooler, but they could be brought about by the electricity supply or by an incorrect use of the water cooler.

In the **ANOMALY** column, the problems reported by the customer are listed.

In the **POSSIBLE CAUSES** column, the "probable reasons" behind the problem are listed.

In the **INTERVENTION** column, the corresponding corrective action is listed.

EN 10.2 COOLING SYSTEM

ANOMALY	POSSIBLE CAUSE	INTERVENTION
the compressor will not start	- power failure	- check that there is voltage in the plug
	- thermostat on the off position, or set to the minimum	- adjust the thermostat position
	- faulty thermostat	- replace the thermostat
	- the over-load protection of the compressor is faulty	- replace it
	- the starting relay is faulty	- replace it
	- the starting capacitor is faulty	- replace it
	- the compressor is faulty	- replace it
the water is cold but the appliance is operating excessively or non-stop	- little ventilation	- place the appliance away from the wall
	- the condenser is dirty or covered	- clean the condenser or free it of its obstacles
	- the thermostat is on maximum cold position	- adjust it
	- the room temperature is higher than 32°C	- it is normal that the appliance works at a continuously high room temperature
the compressor works continuously, but the water is not cold	- gas leak from the cooling system	- contact a specialised technician (refrigerationist)
	- the compressor is faulty	- replace the compressor
COOLING SYSTEM		
too much noise coming from the appliance, but it is working normally	- the machine is not levelled	- level the appliance using the adjustable feet
	- a few pipes are touching some parts inside the appliance, thus causing it to vibrate	- adjust the position of the pipes, making sure they do not touch any other parts
cold water comes out slowly or not at all	- low pressure of the inlet water	- take steps to increase the pressure (autoclave)
	- faulty solenoid valve	- replace it
	- clogged water filter	- replace it
	- the temperature adjuster is faulty and causes complete freezing of the ice compartment	- make the ice melt. replace the temperature adjuster

CARBONATING SYSTEM		
the carbonated water is not very fizzy or not at all	- the pressure of the gas in the co2 reducer is set to less than 3 bars	- increase up to 3.5 – 4 bars
	- co2 cylinder empty	- replace it
	- the temperature of the outlet water is high	- adjust the position of the thermostat to maximum
	- air bubbles inside the carbonator	- clean out the carbonator
only gas comes out of the carbonated water outlet	- the level probes are dirty	- control and replace
	- the pump turns continuously	- no water is entering or the water filter is blocked
	- the pump turns continuously, inlet water is present	- the pipe fitting into the carbonator is obstructed. disassemble and clean
	- the pump is blocked or the pump-motor is not working	- check it and replace it
	- the level controller is faulty	- control and replace
- the pump safety device has intervened (no water)	- check that there is pressure in the network disconnect and reconnect the machine from the electrical network to reset it	
continuous dripping from the outlets	- dirty solenoid valve	- disassemble the solenoid valve and clean it
the still water comes out carbonated	- there is a shortage of inlet water	- disassemble and clean or replace